



The SR3, single-stage atmospheric deaerating heater offers uniform heating, while removing up to 99% of the oxygen in the make-up water.



SR3 Deaerating Feedwater Heaters include factory installed pumps and factory installed suction piping. Suction piping includes standard shut-off valve and flexible connector.

FEATURES

- 99% OXYGEN REMOVAL prevents boiler system corrosion and costly retubing
- UNRESTRICTED VENTING assures quick release of liberated gasses and NO BACK PRESSURE for gravity returns
- ATMOSPHERIC DESIGN requires no safety valves or annual inspection
- ELECTRONIC INSTRUMENTATION for modulating level control includes a HART compatible differential pressure transmitter, PID controller, and motorized control valve
- ULTRA SENSITIVE steam regulator provides uniform reliable heating at all loads
- NO PRESSURE DECAY reduces the chance for pump cavitation
- STAINLESS STEEL construction of all internal heating surfaces
- DURATHERM LINING is field renewable and increases the overall system lifespan
- CUSTOM ENGINEERED PACKAGED SYSTEM with low net positive suction head (NPSH) pumps and high quality components insures reliable service and single source responsibility
- HIGH TEMPERATURE returns are used for heating
- LOW PRESSURE returns can flow by gravity back to the deaerator or can be pumped through the makeup nozzle

ADDITIONAL OPTIONS

- Pump discharge piping
- Pump staging
- Combination motor starters

Industrial Steam offers a complete line of atmospheric and pressurized deaerators ranging in size from 3,400 lbs/hr to 100,000 lbs/hr. These systems provide oxygen removal from .03 cc/liter to .005 cc/liter per ABMA testing procedures. Packaged systems from AFS insures that you have all components necessary for operation.

SR3 .03 Atmospheric Deaerating Feedwater Heaters

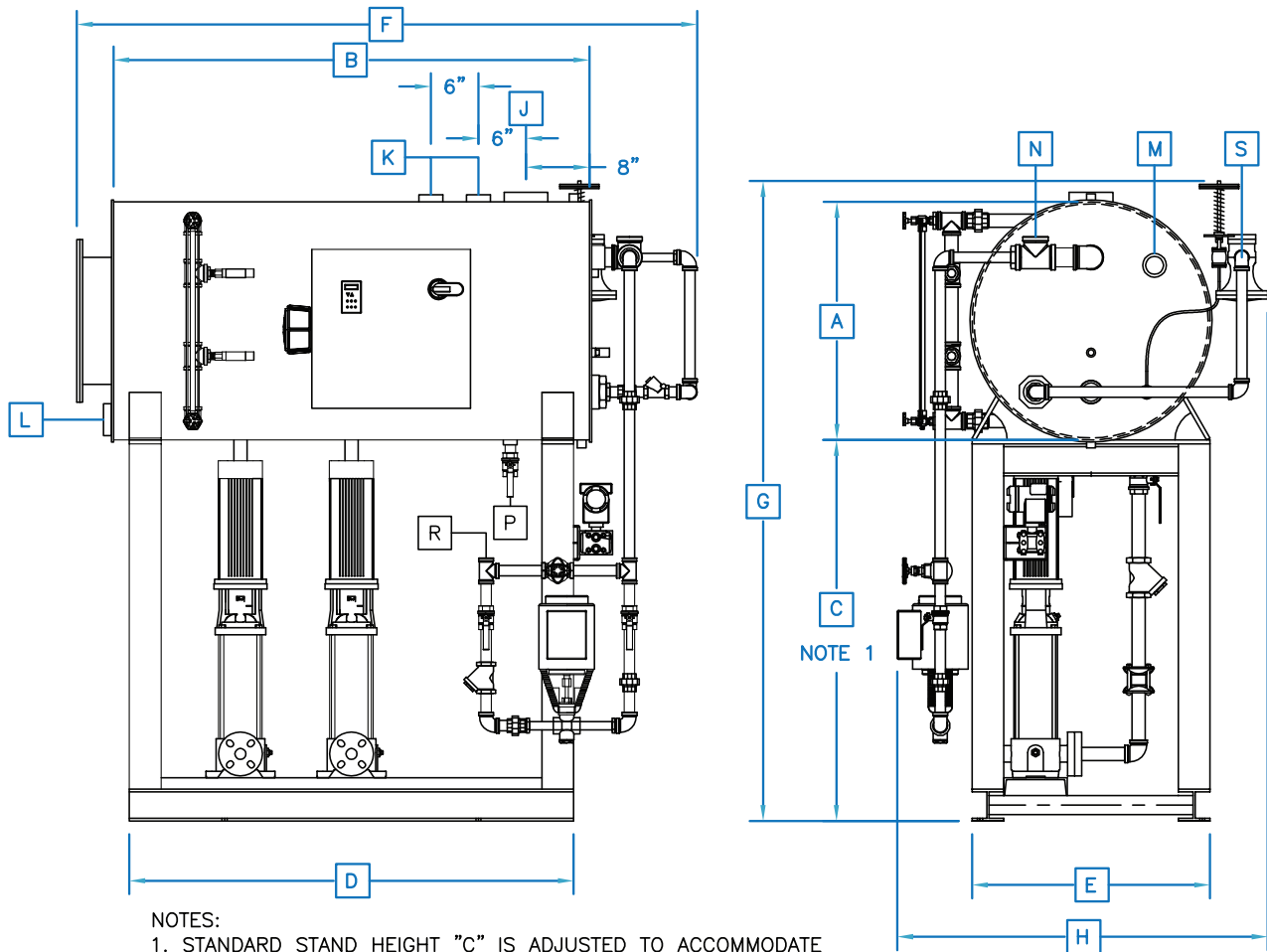

- NOTES:
 1. STANDARD STAND HEIGHT "C" IS ADJUSTED TO ACCOMMODATE SPECIFIC PUMP REQUIREMENTS
 2. WEIGHTS DO NOT INCLUDE PUMPS OR AUXILIARY EQUIPMENT

CAPACITIES & STANDARD DIMENSIONS TABLE

MODEL No.	1SR3	2SR3	3SR3	4SR3	5SR3	6SR3	8SR3	10SR3	12SR3	15SR3	18SR3	21SR3
RATING IN LBS/HR	3,450	6,900	10,350	13,800	17,250	20,700	27,600	34,500	41,400	51,750	62,100	72,450
(A) VESSEL OD	24	30	30	36	36	42	48	48	48	54	60	60
(B) SHELL LENGTH	48	60	83	84	96	84	84	96	120	120	120	144
(C) STAND HEIGHT	48	48	48	48	48	48	48	48	48	48	48	48
(D) STAND LENGTH	48	60	80	80	92	80	80	92	116	116	116	140
(E) STAND WIDTH	24	30	30	36	36	42	48	48	48	54	60	60
(F) OVERALL LENGTH: APPROX	72	84	108	108	120	108	108	120	132	132	132	156
(G) OVERALL HEIGHT: APPROX	84	90	90	96	96	102	108	108	108	114	120	120
(H) OVERALL WIDTH: APPROX	40	46	46	52	52	58	64	64	64	70	76	76
(J) VENT	4	4	4	4	4	4	6	6	6	6	6	6
(K) GRAVITY RETURNS (QTY)	2 (2)	2 (2)	2 (2)	2 (2)	3 (2)	3 (2)	3 (2)	3 (2)	3 (2)	3 (2)	3 (2)	4 (2)
(L) HIGH PRESSURE RETURNS	2	2	2	2	2	2	3	3	3	3	3	3
(M) OVERFLOW	2	2	2	2	2	2	3	3	3	3	3	3
(N) PUMPED RETURNS	2	2	2	2	2	2	2	2	3	3	3	3
(P) DRAIN	1	1	1-1/2	1-1/2	1-1/2	1-1/2	2	2	2	2	2	2
(R) MAKEUP INLET	Sized as Required by Job Conditions											
(P) STEAM INLET												
CAPACITY TO OVERFLOW	110	195	270	390	445	525	690	780	975	1,230	1,570	1,835
MINUTES STORAGE	14.0	13.9	13.0	13.9	12.7	12.6	12.5	11.3	11.8	11.8	12.6	12.6
SHIPPING WT(LBS)	700	1,000	1,225	1,400	1,560	1,985	2,300	2,545	2,985	3,910	4,245	4,850
OPERATING WT(LBS)	1,100	1,770	2,300	2,945	3,325	4,090	5,045	5,685	6,910	8,880	10,375	12,210
FLOODED WT (LBS)	1,490	2,540	3,370	4,490	5,090	6,190	7,790	8,820	10,830	13,840	16,500	19,560

Notes: System Includes 48" stand *Includes 12" for panel **Inlet "K" includes makeup and returns ***Not including boiler feed pumps & panel
 All dimensions in inches